

**USER'S GUIDE**

**N-FX-xx-02 (standard)**

**N-FX-xx-02(L) (low profile)**

100Base-FX, Fast Ethernet Fiber NICs

Transition Networks' N-FX series of fast Ethernet NICs (*Network Interface Cards*) provide a 100Base-FX fiber port to deliver low-cost fiber optic connectivity to the desktop in fiber-rich LAN environments. With both standard and low profile form factors, driver support for most operating systems, and PCI

2.2 plug-and-play capability, these fast Ethernet NICs can be installed in virtually

Part Number	Port One - Duplex Fiber-Optic 100Base-FX
N-FX-ST-02 N-FX-ST-02(L)	ST, 1300 nm multimode, 2 km (1.2 miles)*
N-FX-SC-02 N-FX-SC-02(L)	SC, 1300 nm multimode, 2 km (1.2 miles)*
N-FX-LC-02 N-FX-LC-02(L)	LC, 1300 nm multimode, 2 km (1.2 miles)*
N-FX-MT-02 N-FX-MT-02(L)	MT-RJ, 1300 nm multimode, 2 km (1.2 miles)*
N-FX-SC5-02 N-FX-SC5-02(L)	SC, 1310 nm single mode, 5 km (3.1 miles)*
N-FX-SC20-02 N-FX-SC20-02(L)	SC, 1310 nm single mode, 20 km (12.4 miles)*
N-FX-SB201-02 N-FX-SB201-02(L)	SC, 1310 TX/1550nm RX single mode, single fiber 20 km (12.4 miles)*
N-FX-SB202-02 N-FX-SB202-02(L)	SC, 1550 TX/1310 nm RX single mode, single fiber 20 km (12.4 miles)*

**Optional accessories sold separately**

Part Number	Description
BTR-NFX	Boot ROM chip supports BBS ( <i>Bios Boot specification</i> ) and non-BSS compliant PCs.

\*Typical maximum cable distance. Actual distance is dependent upon the physical characteristics of the network installation.

Installation . . . . .	2
Cable Specifications . . . . .	4
Technical Specifications . . . . .	5
Troubleshooting . . . . .	6
Contact Us . . . . .	7

## Installation

### Checklist

Before installing the N-FX module, verify that the package contains the following items:

- N-FX module
- LAN driver CD

Please notify your sales representative if any item is missing or damaged.

### Description

The N-FX module has a bootable ROM socket (*ROM chip sold separately*). The two LED indicators, LINK/ACT and FDX located on the bracket, show network/board link, activities, collision, and full-duplex statuses. See Figure 1.

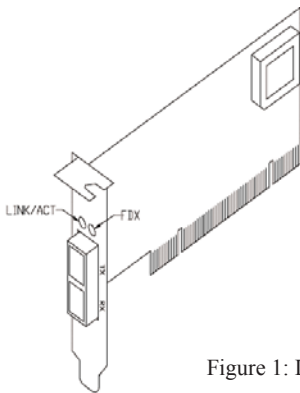

Figure 1: LEDs and Boot ROM Socket

### N-FX module installation

**CAUTION:** Wear a grounding strap and observe electrostatic discharge precautions when installing the N-FX module. Failure to observe this caution could result in damage or failure of the N-FX module.

To install the N-FX module, do the following:

**Important:** Install the N-FX module in a “master slot” only.

1. Locate a master slot on the PC workstation or file server.
2. Remove the cover from the PC workstation or file server—keep all screws.
3. Remove and keep the screws holding the cover over the installation slot.
4. Carefully slide the N-FX module into the “master slot,” aligning the module with the slot guides.

### Install the N-FX module -- continued

5. Ensure that the module is firmly seated in the slot.
6. Use the screws from step “3” to secure the module to the workstation or file server housing.

### N-FX PCI module configuration

For motherboards with automatic PCI configuration:

- No specific setup is needed.
- You can enter the system BIOS setup menu to view or specify the interrupt (INT) line of the PCI slots.

For motherboards with bus master and interrupt jumpers:

- Enable bus master operation in a selected PCI slot and select an INT request line (IRQ) level, using the appropriate motherboard jumper.
- Enable I/O on the N-FX, PCI slot.

### PCI bus system and configuration

- Ensure that the PCI machine supports master slots, and INT multiple sharing and timing compatibility.
- DO NOT install N-FX in PCI slave slots. Please refer to your PC system manual and select the appropriate configuration settings.
- When installing multiple N-FX modules in a server station, you should correctly configure the IRQ settings of the PCI slot.
- Up to four N-FX modules can be installed in a PCI file server running NetWare operating system.
- N-FX server modules share the same INT line with the driver supporting multiple INT services at a time. The IRQ of each N-FX module should not conflict with other boards.
- Operation in full or half-duplex (*default*) mode is configured by LAN driver options. The operating mode should match the working status of the remote link device.
- Use EMM386 version 4.49 or higher, and install both DOS and EMM386 from the same DOS package to avoid software problems.

## Cable Specifications

### Fiber cable

Bit error rate:	<10 <sup>-9</sup>
Single mode fiber ( <i>recommended</i> ):	9 μm
Multimode fiber ( <i>recommended</i> ):	62.5/125 μm
Multimode fiber ( <i>optional</i> ):	100/140, 85/140, 50/125 μm

N-FX-ST-02(x), N-FX-SC-02(x), N-FX-LC-02(x), N-FX-MT-02(x)

	1300 nm multimode
Fiber optic transmitter power:	min: -19.0 dBm max: -14.0 dBm
Fiber optic receiver sensitivity:	min: -31.0 dBm max: -17.0 dBm
Link budget:	12.0 dB

	1310 nm single mode
Fiber optic transmitter power:	min: -19.0 dBm max: -14.0 dBm
Fiber optic receiver sensitivity:	min: -31.0 dBm max: -7.5 dBm
Link budget:	12.0 dB

	1310 nm single mode
Fiber optic transmitter power:	min: -15.0 dBm max: -8.0 dBm
Fiber optic receiver sensitivity:	min: -31.0 dBm max: 0.0 dBm
Link budget:	16.0 dB

	1310 TX/1550 RX nm single mode
	single stand
Fiber optic transmitter power:	min: -14.0 dBm max: -8.0 dBm
Fiber optic receiver sensitivity:	min: -32.0 dBm max: 0.0 dBm
Link budget:	18.0 dB

	1550 TX/1310 RX nm single mode
	single stand
Fiber optic transmitter power:	min: -14.0 dBm max: -8.0 dBm
Fiber optic receiver sensitivity:	min: -32.0 dBm max: 0.0 dBm
Link budget:	18.0 dB

The fiber optic transmitters on the device meet Class I Laser safety requirements per IEC-825/CDRH standard and comply with 21CFR1040.10 and 21CFR1040.11.

## Technical Specifications

For models N-FX-xx-02 and N-FX-xx-02(L)

Standards:	IEEE 802.3
Expansion bus standard:	PCI 2.1, 2.2
Data rate	100Mbps fiber media
LED:	LINK/ACT ( <i>on the bracket</i> ) ON = communication link; FLASHING = activity on link FDX ( <i>full duplex link</i> ); ON = full duplex link
Drivers:	<ul style="list-style-type: none"> <li>• Windows 95, 98, ME, 2000, 2003. XP, NT4.0</li> <li>• NDIS 2, 3, 4, 5</li> <li>• NetWare Server 3.12, 4.x, 5x, 6.x</li> <li>• Netware DOS Client ODI</li> <li>• MAC OS</li> <li>• Linux x86, AMD64</li> <li>• FreeBSD 3.2, 4.x, 5.x</li> <li>• SOC Unixware 7.1, OpenUnix 8</li> <li>• SCO Open Server 5.0.x</li> <li>• Solaris 8, 9, 10</li> </ul>
Boot server support:	PXE, RPL, Netware NCP/IPX, DHCP, BootP
PCB dimensions:	2.2"W x 4.8"D x 0.9"H (55.9 mm x 121.9 mm x 23 mm)
Weight:	3 oz. (91g) approximate
Power consumption:	1.0A @ +5VDC
MTBF	184,743 hours ( <i>Bellcore 7 V5.0</i> )
Operating temp:	0°C to 50°C (32°F to 122°F)
Storage temp:	-25°C to 85°C (-13°C to 185°F)
Humidity:	5% to 90%, non-condensing
Altitude:	0 to 10,000 feet
Warranty:	Lifetime

**WARNING:** Visible and invisible laser radiation when open: DO NOT stare into the beam or view directly with optical instruments. Failure to observe this warning could result in damage to your vision or blindness.

**CAUTION:** Use of controls, adjustments, or the performance of procedures other than those specified herein may result in hazardous radiation exposure.

The information in this manual is subject to change without further notice.

## Troubleshooting

### Diagnostics LEDs and Boot ROM

#### LEDS

The LINK/ACT LED lights when a fiber cable or twisted pair cable connection is good. It blinks to indicate activity.

The collision and full-duplex LED report board operating status.

#### Boot ROM

To add the remote boot feature to a workstation, insert the Boot ROM into the ROM socket. See Figure 1 on page 2.

After power UP, the LINK/ACT LED should light; if not, check the following:

- 1 Confirm that the N-FX module is properly inserted into the master slot.
- 2 Confirm that the PC is properly connected to a power source and with the power source turned ON.
- 3 Check the fiber cable for proper connection.
- 4 Contact Tech Support: 1-800-260-1312, Int'l: 00-1-952-941-7600 if those steps fail to produce the desired result.

**Note:** To connect this device to a router, bridge, or switch, please refer to the corresponding technical manual for the device.

## Contact Us

#### Technical support

Technical support is available at [techsupport@transition.com](mailto:techsupport@transition.com)

- US and Canada: 1-800-260-1312 (24 hours)
- International: 00-1-952-941-7600 (24 hours)

#### Transition now

Chat live via the Web with Transition Networks Technical Support. Log onto [www.transition.com](http://www.transition.com) and click the Transition Now link.

#### Web-based seminar



Transition networks provides seminars via live, web-based training. Log onto [www.transition.com](http://www.transition.com) and click the Learning Center link.

#### Email

Ask a question anytime by sending an email to our technical support staff: [techsupport@transition.com](mailto:techsupport@transition.com)

#### Address

Transition Networks  
6475 City West Parkway  
Minneapolis, MN 55344, U.S.A.  
Telephone: 952-941-7600,  
Toll free: 800-526-9267  
Fax: 952-941-2322

	<b>Declaration of Conformity</b>
<b>Name of Mfg:</b>	Transition Networks, 6475 City West Parkway, Minneapolis, MN 55344 U.S.A.
<b>Model:</b>	N-FX-xx-02 and N-FX-xx-02(L) Network Interface Cards
<b>Part Number:</b>	N-FX-ST-02(x), N-FX-SC-02(x), N-FX-LC-02(x) N-FX-MT-02(x), N-FX-SC5-02(x), N-FX-SC20-02(x), N-FX-SB201-02(x), N-FX-SB202-02(x)
<b>Regulation:</b>	EMC Directive 89/336/EEC
<b>Purpose:</b>	To declare that the N-FX-xx-02 and N-FX-xx-02(L), to which this declaration refers, is in conformity with the following standards:
	CISPR 22:1997+A1:2000; EN 55022:1998+A1:2000 Class A; FCC Part 15 Subpart B; 21CFR subpart J
	I, the undersigned, hereby declare that the equipment specified above conforms to the above Directive(s) and Standard(s).
	June 30, 2005
Stephen Anderson, Vice-President of Engineering	Date

---

## Compliance Information

CISPR22/EN55022 Class A, CE Mark, CISPR22/EN55022 Class A + EN55024, CE Mark

### FCC regulations

This equipment has been tested and found to comply with the limits for a Class A digital device, pursuant to part 15 of the FCC rules. These limits are designed to provide reasonable protection against harmful interference when the equipment is operated in a commercial environment. This equipment generates, uses, and can radiate radio frequency energy and, if not installed and used in accordance with the instruction manual, may cause harmful interference to radio communications. Operation of this equipment in a residential area is likely to cause harmful interference, in which case the user will be required to correct the interference at the user's own expense.

### Canadian regulations

This digital apparatus does not exceed the Class A limits for radio noise for digital apparatus set out on the radio interference regulations of the Canadian Department of Communications.  
Le présent appareil numérique n'émet pas de bruits radioélectriques dépassant les limites applicables aux appareils numériques de la Class A prescrites dans le Règlement sur le brouillage radioélectrique édicté par le ministère des Communications du Canada.

### European regulations

**Caution:** This is a Class A product. In a domestic environment this product may cause radio interference in which case the user may be required to take adequate measures.

**Achtung!** Dieses ist ein Gerät der Funkstörgrenzwertklasse A. In Wohnbereichen können bei Betrieb dieses Gerätes Rundfunkstörungen auftreten. In diesem Fall ist der Benutzer für Gegenmaßnahmen verantwortlich.

**Attention!** Ceci est un produit de Classe A. Dans un environnement domestique, ce produit risque de créer des interférences radioélectriques, il appartiendra alors à l'utilisateur de prendre les mesures spécifiques appropriées.



In accordance with European Union Directive 2002/96/EC of the European Parliament and of the Council of 27 January 2003, Transition Networks will accept post usage returns of this product for proper disposal. The contact information for this activity can be found in the 'Contact Us' portion of this document.



**CAUTION: RJ connectors are NOT INTENDED FOR CONNECTION TO THE PUBLIC TELEPHONE NETWORK. Failure to observe this caution could result in damage to the public telephone network.**

**Der Anschluss dieses Gerätes an ein öffentliches Telekommunikationsnetz in den EG-Mitgliedstaaten verstößt gegen die jeweiligen einzelstaatlichen Gesetze zur Anwendung der Richtlinie 91/263/EWG zur Angleichung der Rechtsvorschriften der Mitgliedstaaten über Telekommunikationsendeinrichtungen einschliesslich der gegenseitigen Anerkennung ihrer Konformität.**

### Trademark notice

All registered trademarks and trademarks are the property of their respective owners.

### Copyright restrictions

© 2004-2005 Transition Networks. All rights reserved. No part of this work may be reproduced or used in any form or by any means—graphic, electronic or mechanical—without written permission from Transition Networks